

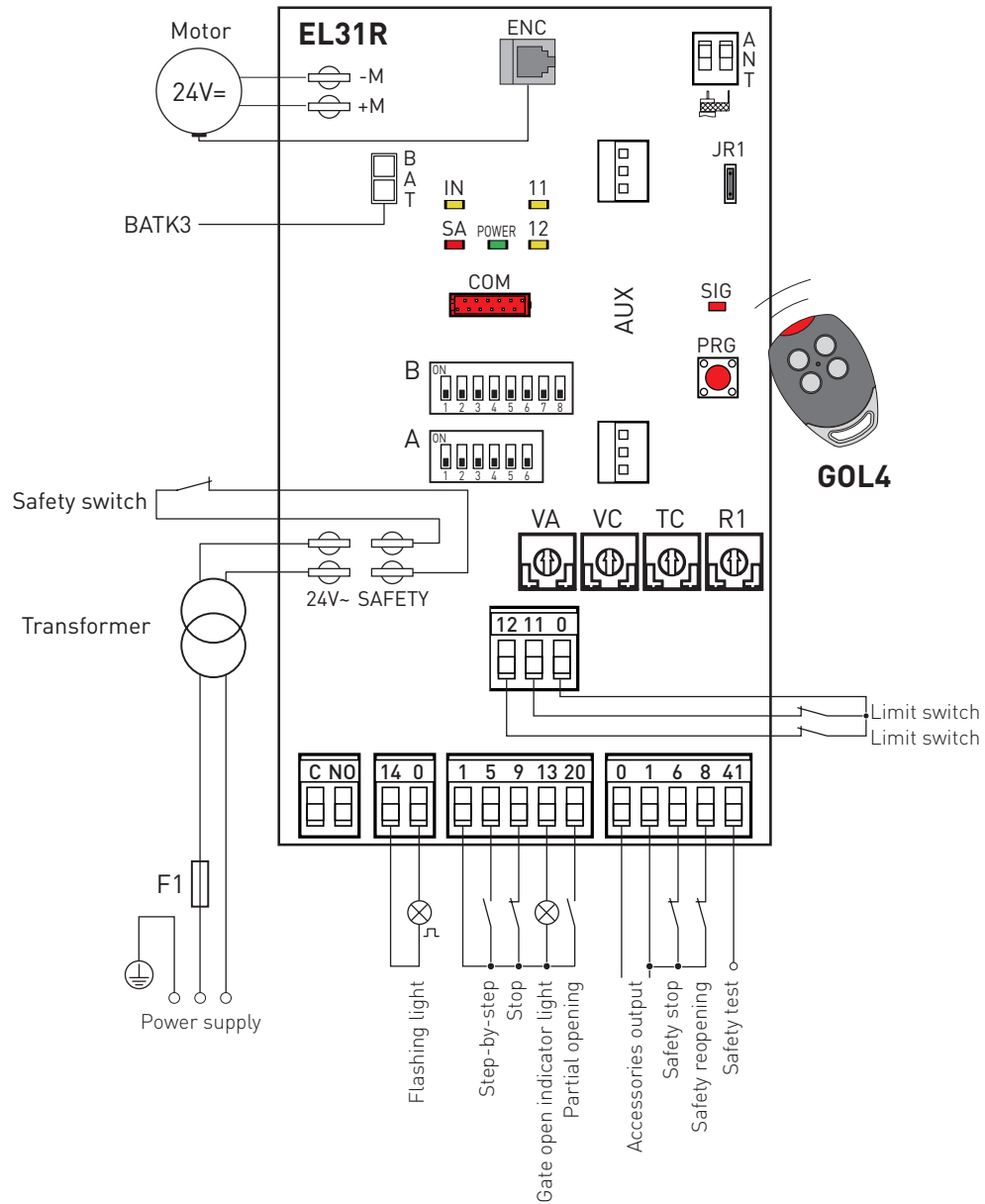











Ditec EL31R

IP1851EN



Installation Manual for control panel for 24V_~ automations with built-in radio.



4. Commands

Command	Function	Description	
1  5	N.O.	STEP-BY-STEP WITH AUTOMATIC CLOSING With DIP1A=OFF and TC<MAX, closing of the contact activates an opening or closing operation in the following sequence: opening-stop-closing-opening. N.B.: the stop is not permanent, but has the duration set with the TC trimmer.	
		STEP-BY-STEP WITHOUT AUTOMATIC CLOSING With DIP1A=OFF and TC=MAX, closing of the contact activates an opening or closing operation in the following sequence: opening-stop-closing-opening.	
		OPENING WITH AUTOMATIC CLOSING With DIP1A=ON and TC<MAX, closing of the contact activates an opening operation.	
		OPENING WITHOUT AUTOMATIC CLOSING With DIP1A=ON and TC=MAX, closing of the contact activates an opening operation. N.B.: Once the automation stops, command 1-5 performs the opposite operation to the one performed before the stop.	
1  6	N.O.	CLOSING With DIP2B=OFF, closing of the contact activates a closing operation.	
1  6	N.C.	OPENING SAFETY CONTACT With DIP2B=ON, opening of the safety contact stops and prevents any movement.	
1  8	N.C.	REVERSAL SAFETY CONTACT Opening the safety contact triggers a reversal of the movement (reopening) during the closing operation.	
1  9	N.C.	STOP Opening the safety contact stops the current operation.	
1  9	N.O.	OPERATOR PRESENT CONTROL Opening of contact 1-9 enables the operator present function. - opening with operator present 1-5 [with DIP1A=ON and TC=MAX]; - closing with operator present 1-6 [with DIP2B=OFF]. N.B.: any safety devices, automatic closing and plug-in cards in the AUX housing are disabled.	
CROSS	1  20	N.O.	PARTIAL OPENING With DIP3B=ON, closing of the contact activates a partial opening operation. Once the automation stops, the partial opening control performs the opposite operation to the one performed before the stop.
	QIK	1  20	N.O.
0  11	N.C.	CLOSING LIMIT SWITCH Opening of the contact stops the closing operation.	
0  12	N.C.	OPENING LIMIT SWITCH Opening of the contact stops the opening operation.	
41 		SAFETY TEST With DIP6A=ON, connecting terminal 41 enables a safety edge test cycle before every operation. If the test fails the SA LED flashes and the test is repeated.	
	N.C.	SAFETY SWITCH The SAFETY SWITCH contact is connected to the release system of the automation. Opening the release contact stops the operation.	

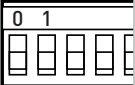
6. Barrier outputs and accessories

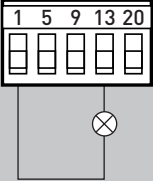
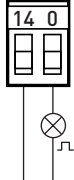
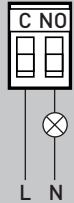
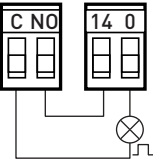
Output	Value - Accessories	Description
	24 V $\overline{\text{DC}}$ 0,3 A	Accessories power supply. Power supply output for external accessories, including automation status lamps.
AUX	SOFA1-SOFA2 GOPAV	The control panel is fitted with a housing for a plug-in card, such as radio receivers, magnetic loops, etc. Operating of the plug-in card is selected by DIP1A. WARNING: the plug-in cards must be inserted and removed with the power supply disconnected.
	STORAGE MODULE	The storage module allows remote controls to be stored and the type of control panel application to be defined (see TECHNICAL SPECIFICATIONS on page 4). If the control panel is replaced, the storage module being used can be inserted in the new control panel. WARNING: the storage module must be inserted and removed with the power supply disconnected.
	BATK3 2x12 V 2Ah	Barrier operation. The batteries are kept charged when the power supply is on. If the power supply is off, the panel is powered by the batteries until the power is re-establish or until the battery voltage drops below the safety threshold. The panel turns off in the last case. WARNING: the batteries must always be connected to the control panel for charging. Periodically check the efficiency of the batteries. N.B.: the operating temperature of the rechargeable batteries is approximately +5°C/+40°C.
	24 V $\overline{\text{DC}}$ 3 W	Automation status lamp (proportional) The light goes off when the automation is closed. The light comes on when the automation is open. The light flashes with a variable frequency while the automation is operating.
	LAMPH 24 V $\overline{\text{DC}}$ 25 W	Flashing light. WITH DIP5A=OFF it is activated during the opening and closing operations.
	230 V~ 400 W	External courtesy light. With DIP5A=OFF, a courtesy light can be connected in series to the NO contact, which activates for 180 s on each opening (total or partial), step-by-step and closing command.
	LAMPH 24 V $\overline{\text{DC}}$ 25 W	Flashing light. WITH DIP5A=ON it is activated during the opening and closing operations.



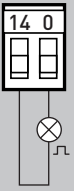
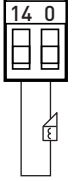

WARNING: use a double insulated cable



Output	Value - Accessories	Description
	QIKLUX 24 V $\overline{\sim}$ 300 mA max	Lighting kit. With DIP5A=ON, on with barrier closed, flashing with barrier operating and off with barrier open.
	QIKAFE 24 V $\overline{\sim}$ 300 mA max	Electric block. With DIP5A=ON it is activated with the barrier closed.

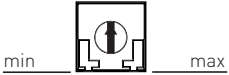
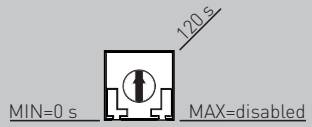
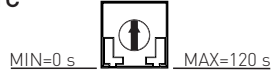

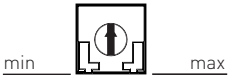
7. Settings

7.1 Trimmers



Trimmer	Description
VA - VC 	VA - Opening speed adjustment. Adjusts the opening speed. VC - Closing speed adjustment. Adjusts the closing speed.
TC 	Setting automatic closing time. From 0 to 120 s. With DIP3A=OFF, once a safety switch has been activated, the counter starts as soon as the safety switch is released (for example, after passing through the photocells), and lasts for a period of time set with TC (50%). WARNING: with QIK automations, automatic closing is immediate. With DIP3A=ON, the counter starts when automation is opened and lasts for the entire duration set with TC (100%). N.B.: after the activation of the stop command, once contact 1-9 has closed again, automatic closing is only enabled after a total, partial or step-by-step opening command.
TC 	With DIP3B=OFF, permanent closing of contact 1-20 enables automatic closing.
CROSS R1 	Power setting. The control panel is equipped with a safety device that stops motion if an obstacle is encountered during the opening operation and reverses motion during the closing operation.
QIK R1 	Adjustment of power and stop distance. It adjusts the power of the automation. With DIP7B=OFF, it adjusts the closing bar stop distance.

7.3 Barrier dip-switches

















DIP A	Description	OFF 	ON 
DIP1A	Command functions 1-5. N.B.: it also sets operating on the AUX plug-in card.	Step-by-step	Opening.
DIP2A	Selecting opening direction. The opening direction is intended by viewing the automation from the side being examined.	Opening to the right.	Opening to the left.
DIP3A	Automatic closing time restore	0%	100%
DIP4A	Automation status at power on. Indicates how the control panel considers automation when powered up.	Open. N.B.: with limit switches installed, we recommend setting DIP4A=OFF.	Closed. N.B.: if the automatic closing function is not used, we recommend setting DIP4=ON.
DIP5A	Operating of output 0-14 and C-NO contact.	Flashing light and courtesy light.	Flashing light, lighting kit and electric block.
	Preflashing for 3 seconds.	Enabled only with automatic closing with TC >3 s.	
DIP6A	Safety test terminal 41.	Disabled.	Enabled.

DIP B	Description	OFF 	ON 
DIP1B	Reversal safety contact operation.	With automation stopped and contact 1-8 open, opening operations are permitted.	With automation stopped and 1-8 open, all operations are disabled.
DIP2B	Command functions 1-6.	Closing.	Stop.
DIP3B	Preflashing for 3 seconds. After intervention of safety switch 1-8 and with immediate closing DIP3A=OFF	Disabled	Enabled
DIP4B	Selection of maximum working forces limit and adjustment of stop distance.	Normal closing force and reduced stop distance that changes according to speed.	Reduced closing force and longer stop distance irrespective of speed.
DIP5B	Stopping type selection.	Immediate.	Normal.
DIP7B	Stop distance adjustment during closing.	It allows the adjustment of the stop distance by means of trimmer R1.	Stopping fixed at 30°.
DIP8B	Electronic antifreeze system. Maintains motor efficiency even at low ambient temperatures.	Enabled.	Disabled.

7.4 Jumper

Jumper	Description	OFF 	ON 
JR1	Built-in radio receiver	Disabled	Enabled

7.5 Signals

LED	On	Flashing
POWER ALARM 	Power supply on.	<p> Encoder not working or DIP5B selection is not consistent with the encoder actually being or not being there.</p> <p> Current overload on flashing light output.</p> <p> Shortcircuiting of flashing light driver.</p>
IN 	Command received or change in status of a dip-switch.	/
SA 	At least one of the safety contacts is open. 1-9 contact is open. DIP6A selection is not consistent with the connection of terminals 6-8.	<p> Safety test failure (terminal 41).</p> <p>Operations count performed (only when control panel is switched on):</p> <p> = 1000 operations</p> <p> = 10000 operations</p>
11 	0-11 limit switch contact is open.	/
12 	0-12 limit switch contact is open.	/
SIG 	Transmitter enabling/storage phase.	<p> Radio transmission of a stored remote control received.</p> <p> Radio transmission of an unstored remote control received.</p> <p> Transmitter being cancelled.</p> <p> Damaged storage.</p>

8. Radio

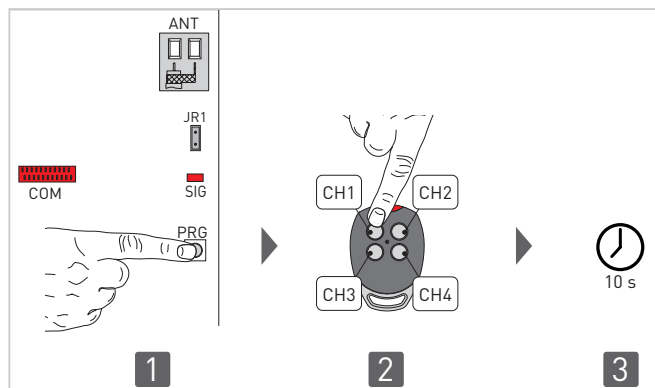

The control panel is equipped with a radio receiver with a frequency of 433.92 MHz.

The antenna consists of a rigid wire, 173 mm long, connected to the ANT clamp.

It is possible to increase the range of the radio by connecting the antenna of the flashing lights, or by installing the tuned BIXAL antenna.

N.B.: To connect the external antenna to the control panel, use a coaxial cable, type RG58 (max. 10 m).

Check that the storage module is inserted in the COM connector.

Up to 100 remote controls can be stored in the storage module.

WARNING: if the radio receiver on the control panel is not used, set JR1=OFF and remove the storage module.

Transmitter storage:

- Press the PRG key on the radio receiver or on the control panel; the SIG indicator LED lights up;
- Proceed with transmission by pressing the CH keys on the remote control that you want to store (within the range of the radio receiver). The remote control is now stored. During this phase, the SIG indicator LED flashes. When the SIG LED comes on again, you can validate another remote control. Validate all the new remote controls by making a transmission as indicated;
- You automatically exit the procedure 10 seconds after the last transmission, or you can press the PRG key again (the SIG LED goes off).

Up to four CH keys of a single remote control can be stored.

- If only one (any) CH key of the remote control is stored, command 1-5 (step-by-step/opening) is carried out;
- If 2-4 CH keys of a single remote control are stored, the functions matched with the CH keys are as follows:
 - CH1 = command 1-5 step-by-step/opening;
 - CH2 = partial opening command, it causes the automation to open for about 1 m;
 - CH3 = command to switch on/off the courtesy light;
 - CH4 = stop command, equivalent to impulsive command 1-9.

Transmitter cancellation:

- Hold down the PRG key for 3 s; the SIG LED starts to flash;
- To cancel all the remote controls from the memory, press the PRG key again, keeping it pressed for 3 s;
- To cancel a single remote control, press any one of the previously memorised CH keys of the remote control to be cancelled;
- The cancellation is confirmed by the quick flashing of the SIG LED.

For further information see the user manual for GOL series remote controls.

If the control panel is replaced, the storage module being used can be inserted in the new control panel.



WARNING: the storage module must be inserted and removed with the power supply disconnected.



For further information see the user manual for GOL series remote controls.

10.2 Starting the barriers



WARNING

The operations related to point 6 are performed without safeties.

The trimmer can only be adjusted with the automation idle.

The automation automatically slows when approaching the end stops or stop limit switches. After start-up the control panel receives a RESET and the first operation is performed at reduced speed (automation position acquisition).

- 1- Make a jumper for NC safety contacts.
- 2- Check that the storage module corresponding to the type of application selected is correctly plugged in.
- 3- Adjust the opening and closing stop limit switches, if any.
N.B.: limit switches must be kept pressed until the operation has been completed.
- 4- Set TC=MAX and R1=50%.
Select the desired opening direction with DIP2A.
Set DIP4B=OFF and DIP6B=OFF.
- 5- Manually move the barrier bar and make sure it is correctly balanced.
- 6- Switch on and check the automation is operating correctly with the subsequent opening and closing commands.
Check that the limit switches are activated if used.
- 7- Connect the safety devices (removing the relative jumpers) and check they function correctly.
- 8- If desired, adjust the automatic closing time with the TC trimmer.
WARNING: the automatic closing time after a safety device has triggered depends on the DIP3A setting.
- 9- Set the desired opening and closing speed with the VA and VC trimmers.
WARNING: with QIK automations, for correct operation with a bar longer than 4.5 m, adjust the VA and VC trimmers to no more than 50%.
- 10- Connect any other accessories and check they are functioning.



N.B.: in the event of servicing or if the control panel is to be replaced, repeat the start-up procedure.

13. Application example for barriers

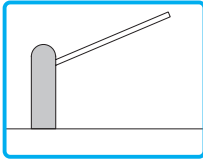

When using the control panel for barrier applications:

- Select the correct opening direction with DIP2A.

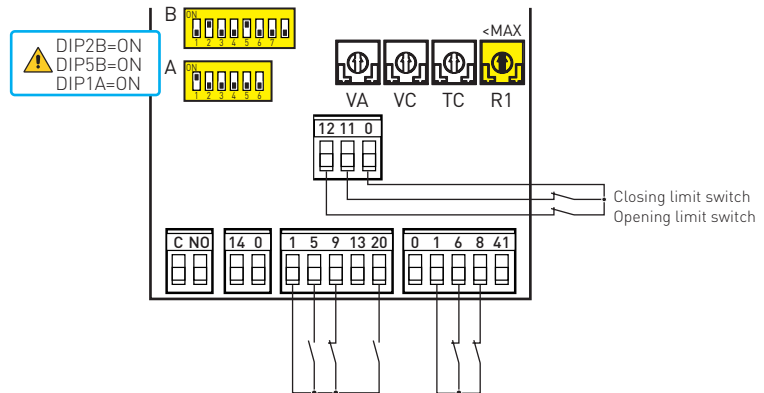

Connect the opening and closing limit switch NC contacts to terminals 0-11-12.

With this configuration, the barrier stops when the limit switches are activated.

14. Operator present function modes

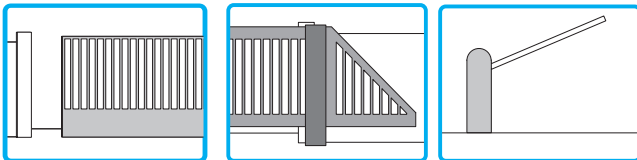

Quando il quadro elettronico viene usato in modalità "uomo presente":

- scollegare il morsetto 9;
- impostare il senso di marcia mediante DIP2A=OFF;

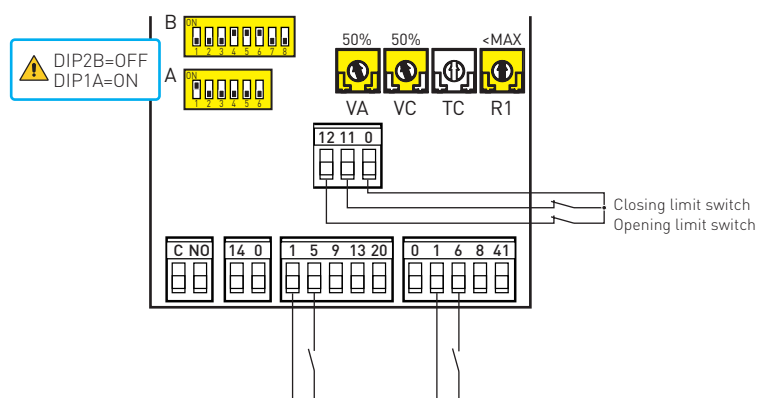

In questa condizione, i comandi di apertura (1-5) e di chiusura (1-6) funzionano solo se mantenuti premuti, al loro rilascio l'automazione si ferma.

La chiusura automatica e i comandi radio sono disabilitati.

15. Example of parallel automations

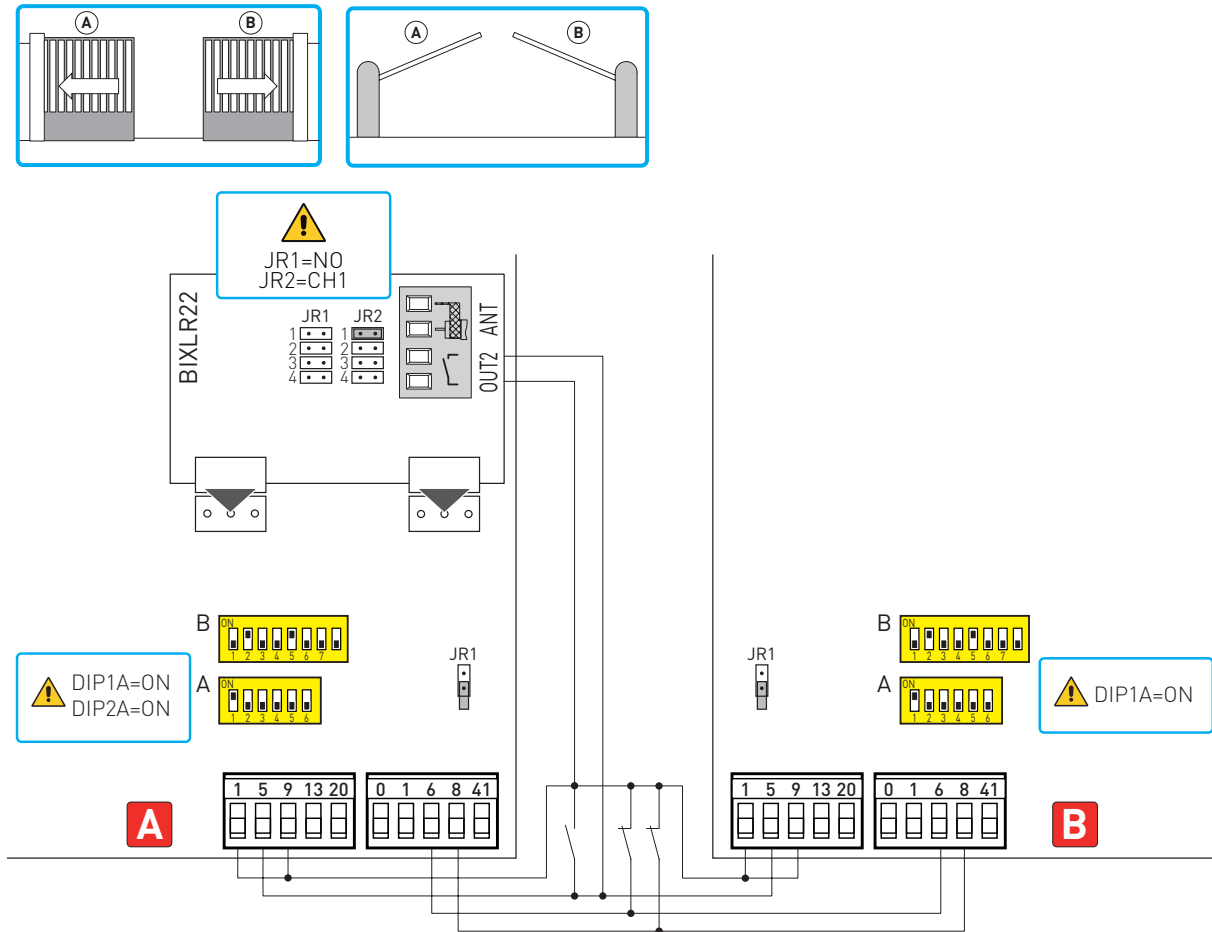

It is possible to command two automations [A] and [B] in parallel with the connections and settings indicated in the figure.

Step-by-step commands (1-5) and radio controls are like an opening command.

To manage both automations with a single remote control, do not use the radio receivers on the control panels (JR1=OFF), but insert a BIXLR22 radio receiver.

Adjust TC, VA and VC trimmers in the same position on both control panels.



N.B.: the opening and closing movements may not be synchronised.