



TM-0037-1 5914420 MAR 2008

**MANUFACTURER'S STATEMENT**

Read this operation manual carefully before use to ensure proper operation of the sensor. Failure to read this operation manual may cause improper sensor operation and may result in serious injury or death of person. The meanings of the symbols are as follows. Please study the following first and then read the contents of this operation manual.

- WARNING** Disregard of warning may cause the improper operation causing death or serious injury of person.
- CAUTION** Disregard of caution may cause the improper operation causing injury of person or damage to objects.

**NOTE** Special attention is required to the section of this symbol.

It is required to check the operation manual if this symbol is shown on the product.

**NOTE**

1. This sensor is a non-contact switch intended for header mount / built-in / wall mount of an automatic door. Do not use for any other applications. This sensor cannot be used for industrial doors or shutters, when used, proper operation and safety cannot be guaranteed.
2. When setting the sensor's detection area, make sure there is no traffic around the installation site.
3. Before turning the power ON, check the wiring to prevent damage or malfunction of equipments that are connected to the sensor.
4. Only use the sensor as specified in the operation manual provided.
5. Be sure to install the sensor in accordance with the local laws and standards of the country in which the sensor is installed.
6. Before leaving the job site make sure that the sensor is operating properly and instruct the building owner/operator on proper operation of the door and the sensor.
7. The sensor settings can only be changed by an installer or service engineer. When changed, the changed settings and dates shall be registered in the maintenance logbook accompanying the door.

**WARNING** Do not wash, disassemble, rebuild or repair the sensor, otherwise it may cause electric shock or breakdown of equipments.  
Danger of electric shock.

**SPECIFICATIONS**

Model	: PASAT3 - PASAT3I	Test input	: Opto coupler
Cover color	: Black (PASAT3 only)	Output hold time	: Voltage / 5 to 30VDC
Mounting height	: 2.0 to 3.0m (6'7" to 9'10")	Response time	: Approx. 0.5sec.
Detection area	: See <b>ADJUSTMENTS</b>	Operating temperature	: -20 to +55°C (-4 to 131°F)
Detection method	: Active Infrared Reflection	Operating humidity	: <80%
Depth angle adjustment	: -5 to 5°	IP rate	: IP44 (PASAT3) / IP4X (PASAT3I)
Power supply *	: 12 to 24VAC (±10%) 12 to 30VDC (±10%)	Category	: 2 (ISO13849-2)
Power consumption	: <3VA	Weight	: 260g / 9.2oz (PASAT3) 175g / 6.02oz (PASAT3I)
Operation LED	: Green / Stand-by Red / Detection active	Accessories	: 1 Cable 3m(9'10") (6 × 0.14mm <sup>2</sup> AWG26 / Overcurrent protection with less than 2A)
Safety / Test output	: Opto coupler (NPN) Voltage / 5 to 50VDC Current / 100mA Max. (Resistance load)		: 1 Operation manual 2 Mounting screws (PASAT3 only) 1 Mounting template (PASAT3 only)

\*When using this sensor, the sensor has to be connected to a door system which has the SELV circuit.

**NOTE** The specifications herein are subject to change without prior notice due to improvements.

**OUTER DIMENTIONS AND PART NAMES**

**PASAT3 : Header mount**

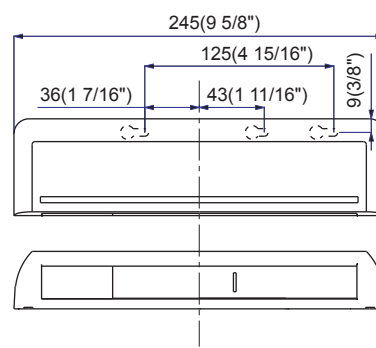

**PASAT3I : Built-in**

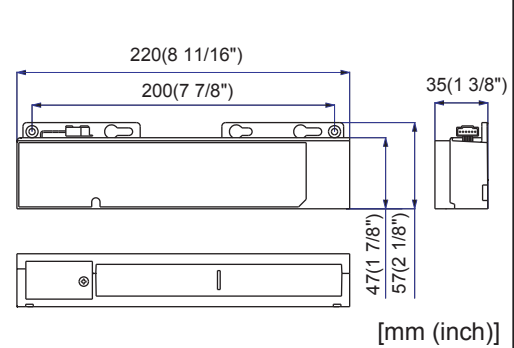

[mm (inch)]

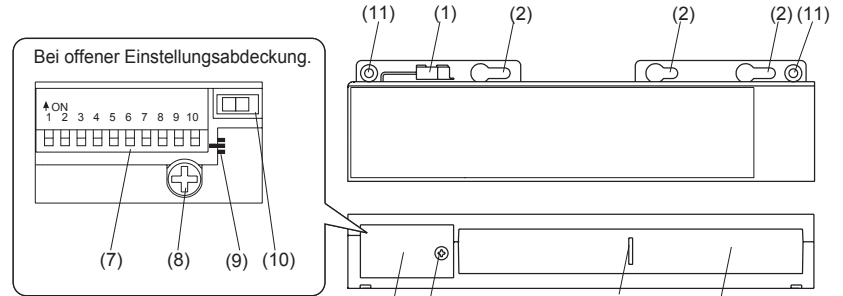

- (1) Connector
- (2) Mounting holes for PASAT3
- (3) Setting cover
- (4) Setting cover screw
- (5) Operation LED
- (6) Detection window
- (7) DIPswitches
- (8) Depth angle adjustment
- (9) Depth angle adjustment screw
- (10) Function key
- (11) Mounting holes for PASAT3I

**INSTALLATION**

- NOTE** The following conditions are not suitable for the sensor installation.
- Fog or exhaust emission around the door.
  - Wet floor.
  - Vibrating header or mounting surface.
  - Moving objects or a heating radiator in the detection area.
  - Highly reflecting floor or highly reflecting objects around the door.

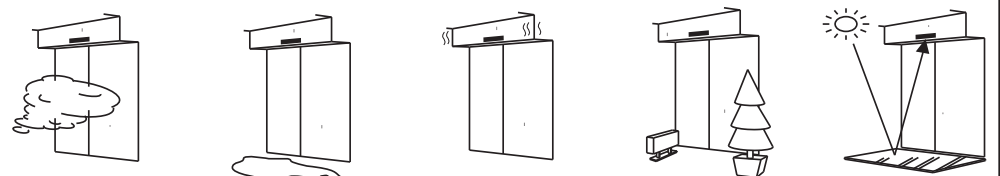

**1 PASAT3**

1. Affix the mounting template at the desired mounting position.
2. Drill two mounting holes of ø3.4mm (ø1/8").
3. To pass the cable through the header, drill a wiring hole of ø8mm (ø5/16").
4. Remove the mounting template.

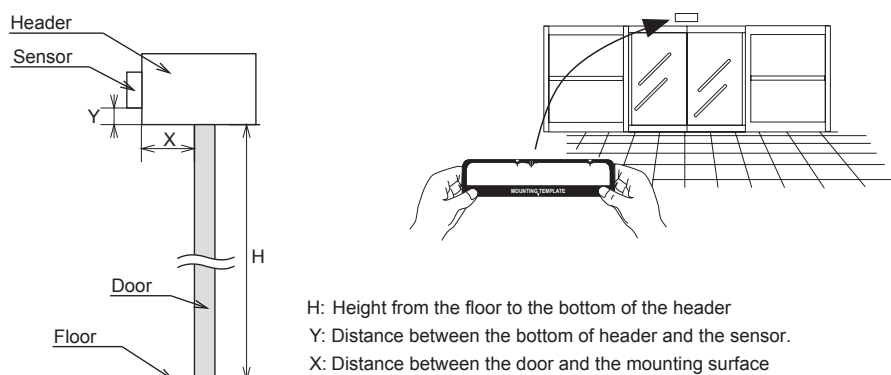

H: Height from the floor to the bottom of the header  
Y: Distance between the bottom of header and the sensor.  
X: Distance between the door and the mounting surface

Maximum mounting distance (Y) [mm(feet,inch)]

X \ H	2,000 (6' 6")	2,200 (7' 2")	2,500 (8' 2")	2,930 (9' 9")
0	No limit			
50 (1 15/16")	45 (1 3/4")	50 (1 15/16")	55 (2 3/16")	70 (2 3/4")
100 (3 15/16")	35 (1 3/8")	40 (1 9/16")	45 (1 3/4")	55 (2 3/16")
150 (5 7/8")	25 (1")	30 (1 3/16")	35 (1 3/8")	40 (1 9/16")
200 (7 7/8")	15 (9/16")	20 (13/16")	25 (1")	35 (1 3/8")
250 (9 13/16")	-	15 (9/16")	20 (13/16")	25 (1")
300 (11 13/16")	-	-	-	15 (9/16")

5. Remove the housing cover by placing the fingers on the notches as shown below. Attach the sensor to the mounting surface with two mounting screws.



**CAUTION** Make sure to affix the mounting template as described in the above chart, otherwise it can be dangerous since there may be no detection area around the threshold. Install the sensor as low as possible on the header.  
Risk of getting caught.

**NOTE** The sensor mounting position may be limited depending on the header thickness and the mounting height. To comply with DIN18650, ensure that the sensor is installed within the values in the above chart and that the mounting height does not exceed 3,000mm (9'10").

**2 PASAT3I**

2. Open the header maintenance cover and mount the sensor as shown.

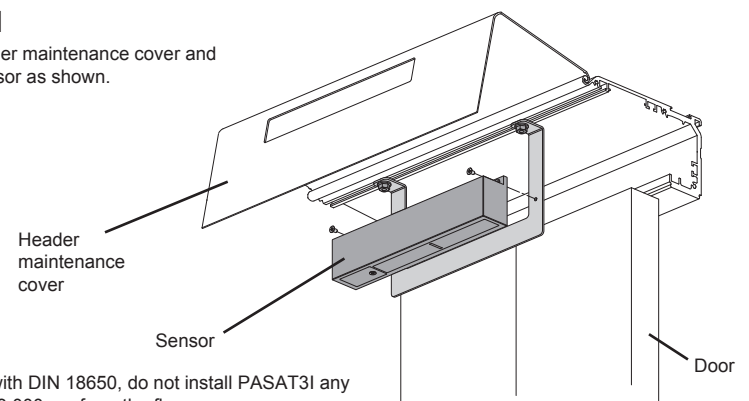

**NOTE** To comply with DIN 18650, do not install PASAT3I any higher than 3,000mm from the floor.

**3 PASAT3 & PASAT3I**

3. Wire the cable to the door controller as shown below.

To connector of the sensor

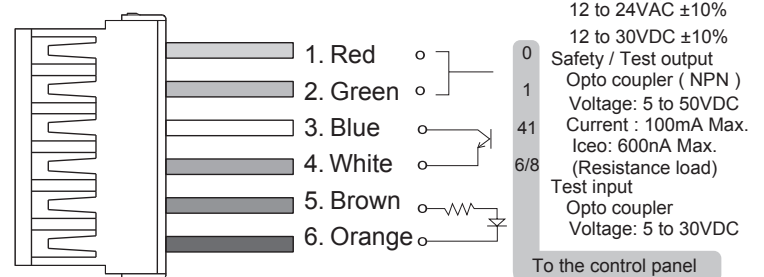

**WARNING** Before starting the procedure, ensure that the power is turned OFF. When passing the cable through the hole, do not tear the shield, otherwise it may cause electric shock or breakdown of the sensor.  
Danger of electric shock.

**4 PASAT3 & PASAT3I**

1. Plug the connector of the sensor.
2. Open the setting cover.
3. Supply power to the sensor. Adjust the detection area and set the dipswitches. ( See **ADJUSTMENTS** )
4. Close the setting cover.

**NOTE** Make sure to connect the cable correctly to the door controller before turning the power ON. To enable the presence detection, do not enter the detection area for 10 seconds after supplying the power. Do not touch the dipswitches before turning the power ON, otherwise an error occurs. When changing the settings of dipswitches, check **ADJUSTMENTS 3 Dipswitch settings**.

**5 PASAT3**

5. Place the housing cover. If wiring is to be exposed, break the knockout.

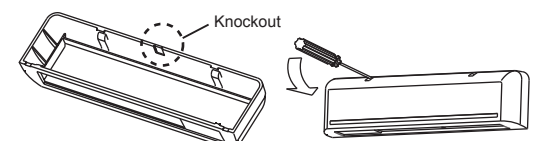

**WARNING** Do not use the sensor without the cover. When using the cable knockout, install the sensor indoors or use the rain-cover (Separately available) otherwise electric shock or breakdown of the sensor may occur.  
Danger of electric shock.

**NOTE** To remove the housing cover of the sensor installed on the header, place a screw driver in the two notches on the upper part of the sensor.

## INSTALLATION

### 6 PASAT3I

Close the header maintenance cover.

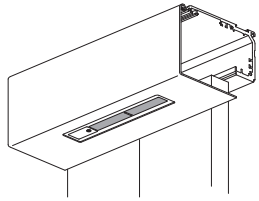

## ADJUSTMENT

### 1 Detection area according to the test conditions required by DIN18650.

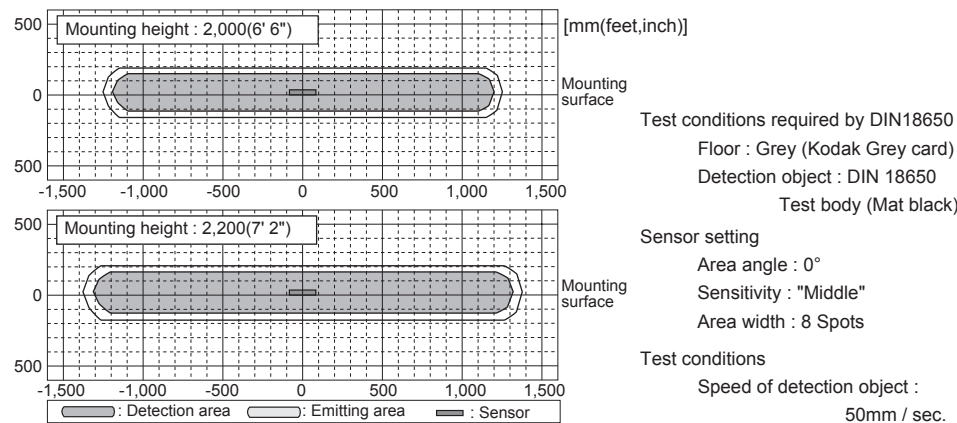

**NOTE** The actual detection area may become smaller depending on the ambient light, the color / material of the object or the floor as well as the entry speed of the object. The sensor may not be activated when the entering speed of the object or a person is slower than 50mm / sec. or faster than 1,500mm / sec.

### 2 Area depth angle adjustment

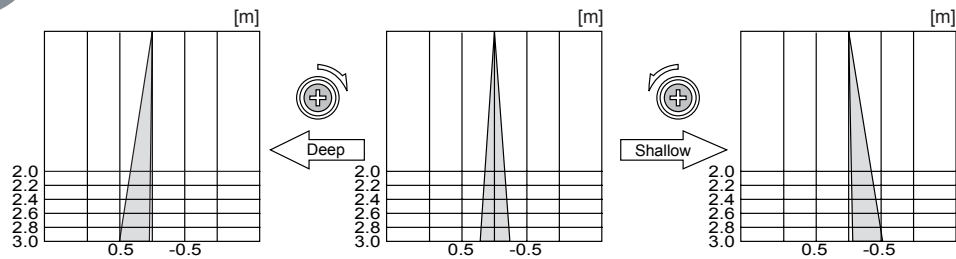

The detection area can be adjusted up to 5° away from the door (Deep) or 5° towards the door (Shallow). Adjust the required detection area by turning the depth adjustment screw with a screw driver. Check the detection area position with Red LED of the Operation LED using a tool such as a reflecting mirror. For the compliance with DIN18650, the required fine adjustments applying the DIN18650 test conditions are recommended.

**NOTE** Make sure the detection area does not overlap with the door / header, otherwise ghosting / signal saturation may occur. Do not place any highly reflecting objects in the detection area, otherwise signal saturation may occur.

### 3 Dipswitch settings

- Follow these steps to change the settings of dipswitches.
1. Change the function key from "Operation Mode" to "Setting Mode".
2. Change the dipswitches setting.
3. Change the function key back to "Operation Mode".

**NOTE** When the above procedures (1-3) are not followed, an error (Red & Green blinking) occurs. Make sure to use the sensor only in "Operation Mode". The sensor does not operate properly in "Setting Mode".

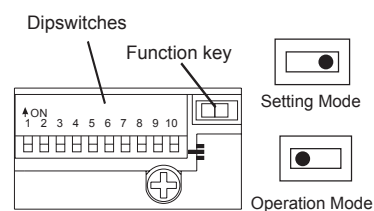

#### 3-1. Setting the sensitivity

Normally set to "Middle". "Low" decreases the sensitivity and "High / S-High" increases the sensitivity. Refer to the chart below for the suitable sensitivity to each installation environment.

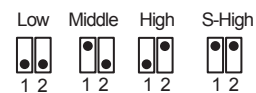

		Mounting height [ mm (feet,inch) ]				For example
		2,000 (6' 6")	2,200 (7' 2")	2,500 (8' 2")	3,000 (9' 10")	
Floor condition	Low reflection	Middle	Middle	High	S-High	-Carpet -Dark color floor
	Middle reflection	Low	Middle	Middle	S-High	-Concrete
	High reflection	Low	Low	Middle	High	-Tile -Marble

**NOTE** Special attention to the setting is required when the door is used often by the elderly or children. Please adjust the sensitivity and presence detection timer according to your risk assessment.

#### 3-2. Setting the presence detection timer

The presence detection timer can be selected from 4 settings. To comply with DIN18650, set the timer "60sec." or longer.



**NOTE** To enable the presence detection, do not enter the detection area for 10 seconds after setting the timer.

#### 3-3. Setting the area width

The left and right width can be adjusted by combining dipswitches 5,6,7 and 8. Referring to the chart below, select dipswitches 5 and 6 for the left and dipswitches 7 and 8 for the right area width adjustment.

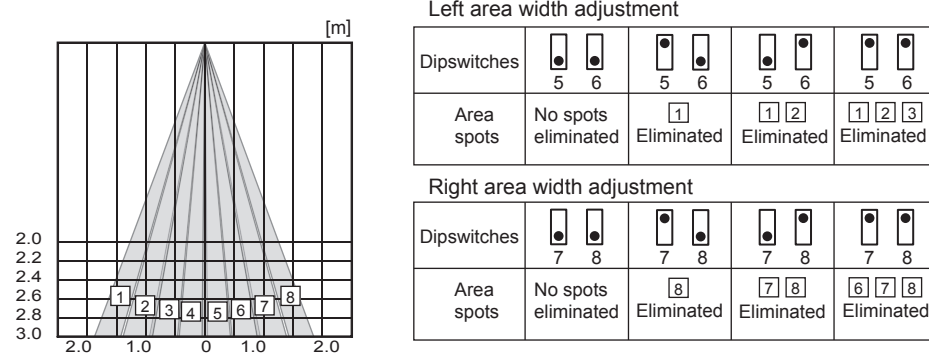

**NOTE** The actual detection area may become smaller depending on the ambient light, the color / material of the object or the floor as well as the entry speed of the object. The sensor may not be activated when the entering speed of an object or a person is slower than 50mm / sec. or faster than 1,500mm / sec.

#### 3-4. Setting the frequency

When using more than two sensors close to each other, set the different frequency for each sensor by dipswitch 9.

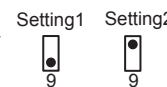

#### 3-5. Setting the test input

Set dipswitch 10 according to the test input from the door controller.



< Test input and Safety / Test output timing chart >

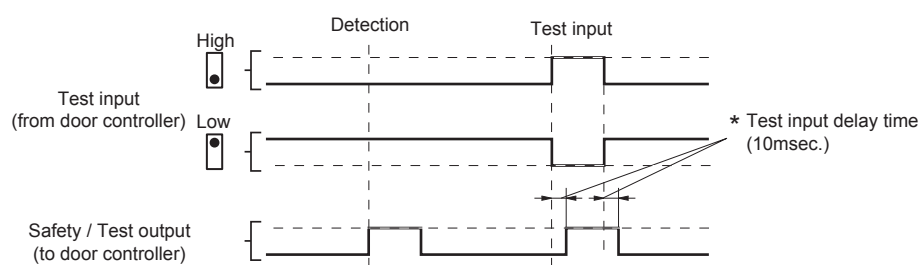

\*The test input delay time is the time period between the test input and safety / test output.

## CHECKING

Check the operation according to the chart below.

	Power OFF	Outside of detection area	Entry into detection area	Outside of detection area
Entry				
Status	-	Stand-by	Motion/Presence detection active	Stand-by
Operation LED	None	Green	Red	Green
Output	OFF	ON	OFF	ON

## COMPLIED STANDARDS

DIN 18650-1:2005	DIN 18650-2:2005	EN 12978:2003
EN 954-1:1997	ISO13849-2:2003	prEN 12650-1:1999 prEN 12650-2:1999

## INFORM BUILDING OWNER / OPERATOR OF THE FOLLOWING ITEMS

### WARNING

- Always keep the detection window clean. If dirty, wipe the window lightly with a damp cloth. (Do not use any cleaner or solvent.)
- Do not wash the sensor with water.
- Do not disassemble, rebuild or repair the sensor yourself, otherwise electric shock may occur.
- When an operation LED blinks green, contact your installer or service engineer.
- Always contact your installer or service engineer when changing the settings.
- Do not paint the detection window.

- When turning the power ON, always walk-test the detection area to ensure proper operation.
- Do not place any objects that move or emit light in the detection area. (e.g. Plant, illumination, etc.)

## TROUBLESHOOTING

Problem	Operation LED	Possible cause	Possible countermeasures
Door does not open when a person enters the detection area.	None	Power supply voltage. Wrong wiring or connection failure.	Set to the stated voltage. Check the wires and connector.
	Unstable	Wrong detection area positioning.	Check <b>ADJUSTMENTS 1, 2 &amp; 3</b> .
		Sensitivity is too low.	Set the sensitivity higher.
		Short presence detection timer. Dirty detection window.	Set the presence detection timer longer. Wipe the detection window with a damp cloth. (Do not use any cleaner or solvent.)
Door opens when no one is in the detection area. (Ghosting)	Unstable	Vibration of the header.	Set the sensitivity lower.
		Water drops on the detection window.	Use the rain-cover (Separately available). Or install in a place keeping the waterdrops off.
	The detection area overlaps with that of another sensor.	Check <b>ADJUSTMENTS 3-4</b> .	
	The detection area overlaps with the door / header.	Adjust the detection area to "Deep" (Outside).	
	Reflecting objects in the detection area. Or reflecting light on the floor.	Remove the objects.	
	Sensitivity is too high.	Set the sensitivity lower.	
	Objects that move or emit light in the detection area. (Ex.Plant, illumination, etc.)	Remove the objects.	
Door remains open	Red	Sudden change in the detection area.	Check <b>ADJUSTMENTS 3-1 &amp; 3-2</b> . If the problem still persists, hard-reset the sensor.(Turn the power OFF and ON again.)
		Wrong wiring or connection failure.	Check the wires and connector.
	Proper	Wrong setting of dipswitches.	Check <b>ADJUSTMENTS 3-5</b> .
		Wrong setting of function key.	Set to "Operation Mode".
	Fast Green blinking	Self monitoring output.	Contact your installer or service engineer.
		Dirty detection window.	Wipe the detection window with a damp cloth. (Do not use any cleaner or solvent.)
Slow Green blinking	Sensitivity is too low.	Set the sensitivity higher.	
	Signal saturation.	Remove highly reflecting objects from the detection area. Or lower the sensitivity. Or change the area angle.	
	The detection area overlaps with the door / header.	Adjust the detection area to "Deep" (Outside).	
Red & Green blinking	Wrong setting of dipswitches.	1. Set the function key to "Setting Mode"	
		2. Change dipswitch 10 setting (ON → OFF → ON or OFF → ON → OFF)	
Door remains closed	Proper	Wrong wiring or connection failure.	Check the wires and connector.
		3. Set the function key back to "Operation Mode".	



Via Mons. Banfi, 3  
21042 Caronno Pertusella (VA)  
Tel. +39 02 963911  
Fax. +39 02 9650314  
ditec@ditecva.com