

- IT** Manuale di installazione sensore a microonde
- EN** Microwave sensor installation manual
- FR** Notice d'installation capteur hyperfréquence
- DE** Bedienungsanleitung für Mikrowellen- Bewegungsmelder
- ES** Manual de instalación del sensor de microondas
- PT** Manual de instalação do radar de microondas

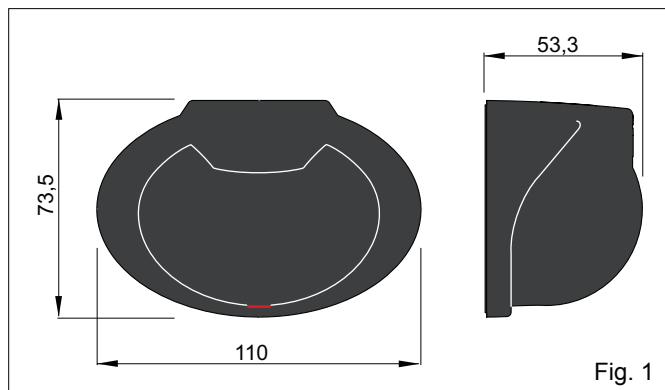

Fig. 1

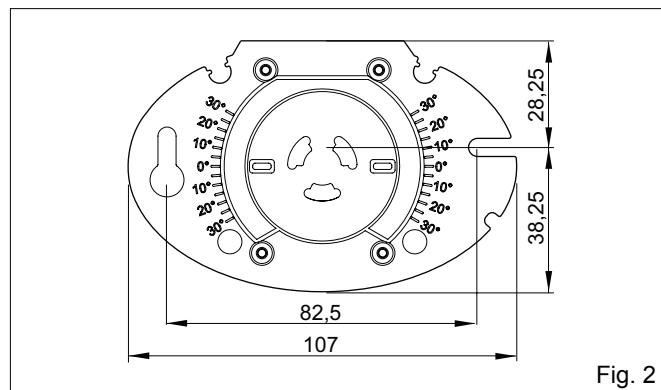

Fig. 2

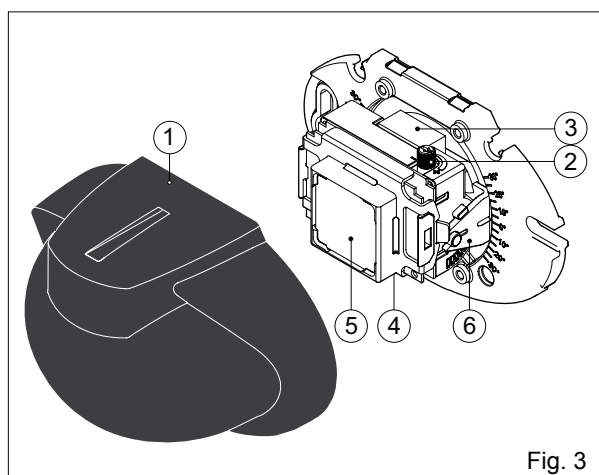

Fig. 3

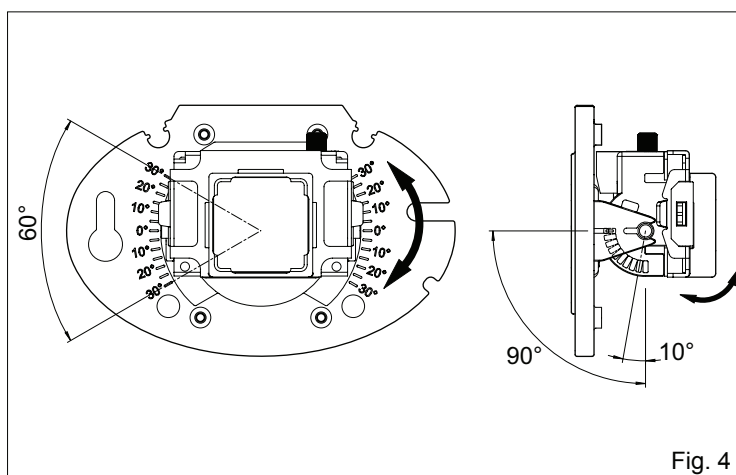

Fig. 4

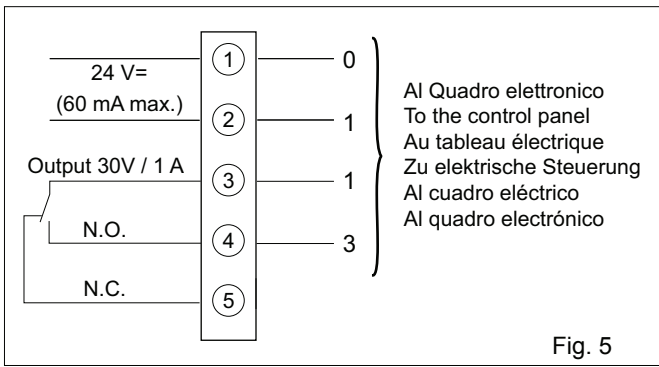

Fig. 5

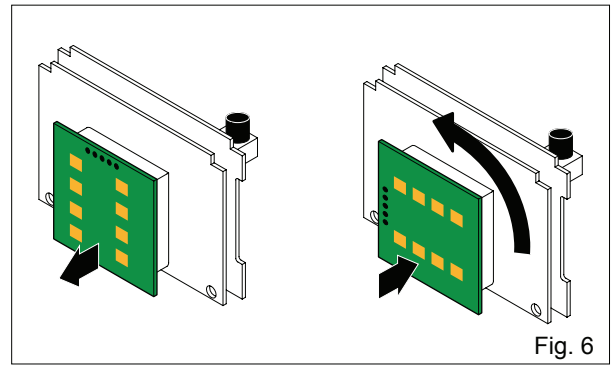

Fig. 6

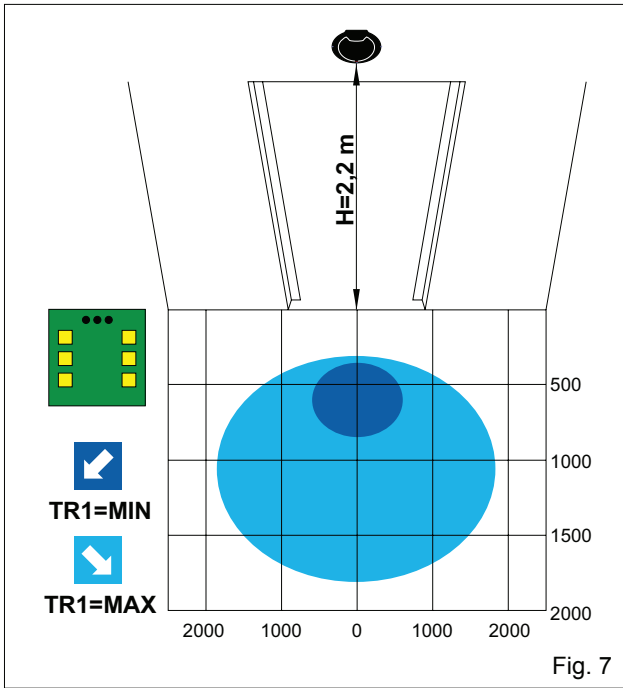

Fig. 7

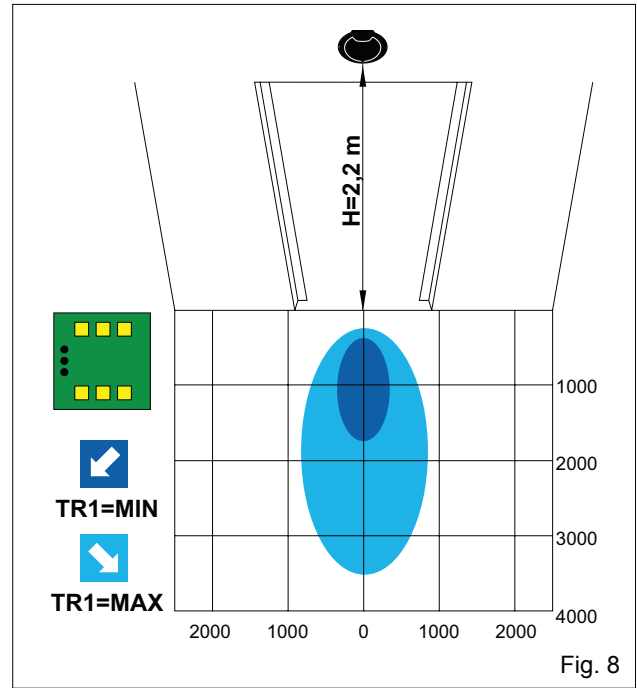

Fig. 8

DECLARATION OF CONFORMITY

Manufacturer: DITEC S.p.A.
via Mons. Banfi, 3
21042 Caronno Pertusella (VA) - ITALY.

Herewith declares that the microwave sensor PASS24 is in conformity with the provisions of the following EC directives:

- R&TTE Directive 1999/5/EC
- EMC Directive 2004/108/EC
- Low Voltage Directive 2006/95/EC.

Caronno Pertusella, 15-03-2010

Silvano Angaroni
(Managing Director)

GENERAL SAFETY PRECAUTIONS

This installation manual is intended for professionally competent personnel only.

Read the instructions carefully before beginning to install the product. Incorrect installation may be a source of danger.

Packaging materials (plastic, polystyrene, etc.) must not be allowed to litter the environment and must be kept out of the reach of children for whom they may be a source of danger.

Before beginning the installation check that the product is in perfect condition.

For repairs or replacements of product only original spare parts must be used. These instructions must be kept and forwarded to all possible future user of the system.



To handle electronic parts, wear earthed antistatic conductive bracelets.

1. TECHNICAL DATA

Power supply	24 V=
Absorption at rest	50 mA
Absorption when detecting	80 mA
Frequency	24,125 GHz
Output contact	30 V / 1 A max (resistive load)
Protection degree	IP54
Temperature	from -20° C to +55° C
Max installation height	3 m

2. REFERENCE

- [1] Cover
- [2] Sensitivity adjustment trimmer
- [3] Command terminal board
- [4] Led / Operation indicator
- [5] Sensor module
- [6] Adjustment bracket

3. INSTALLATION AND FUNCTIONING

(Fig. 3) Remove the cover [1] by inserting a screwdriver in the hole on the upper part of the sensor.

Securely fix the sensor to a flat surface using screws and plugs (not supplied) and position it so that it can monitor the entire area opposite the passage opening.

NOTE: avoid putting any swaying objects - such as curtains, signs or plants - in the detection area. Ensure that rain and snow cannot fall directly onto the sensor or it doesn't detect them, and also that it is not directed towards fluorescent lamps.

	Outside the detection area	Inside the detection area	Outside the detection area
Led (4)	OFF	ON	OFF
Output relay N.O.			

4. ELECTRICAL CONNECTIONS

Make the connections indicated in fig. 5.

WARNING: The product must be connected to an extra-low voltage power source (SELV) which is protected from overcurrent and shortcircuiting.

5. ADJUSTING THE DETECTION AREAS

Selecting the type of detection area.

Choose the required form of the detection area, pointing the sensor module [5] as indicated in figures 7 and 8.

(Fig.6) To select a restricted area, remove the sensor module cover, then remove the sensor module [5] and rotate it by 90° anticlockwise before inserting it in the special connection.

Selecting the depth of the detection area.

The depth can be altered by changing the vertical positioning of the adjustment bracket [6]. In the examples of figures 7 and 8, the vertical angle is 30°.

NOTE: check the sensor does not detect the moving door wing.

Selecting the detection area

The position (towards the right or left) of the detection area is obtained by rotating the adjustment bracket [6] clockwise or anticlockwise.

Adjusting the sensitivity

Adjust the sensitivity of the detection area by means of the sensitivity adjustment trimmer [2], as indicated in figures 7 and 8.

6. TROUBLESHOOTING

Problem	Cause	Solution
It does not work	Power supply voltage	Check the power supply
	Faulty connection	Check the wiring and the connector
It does not always work	Sudden change in the detection area conditions	Check the installation conditions
		Check the direction of the sensor and/or its sensitivity
It works by itself	There is a moving object in the detection area	Remove the object
	Presence of water drops on the cover.	Clean the cover and check the sensor installation
	The sensor detects rainfalls or snowfalls	Check the installation conditions
	The sensor is subject to vibrations	Install the sensor firmly
	The sensor detects the moving door wing	Correctly adjust the detection area and sensitivity with TR1.

All right reserved

All data and specifications have been drawn up and checked with the greatest care. The manufacturer cannot however take any responsibility for eventual errors, omissions or incomplete data due to technical or illustrative purposes.