

PRODUCT TECHNICAL DATASHEET

BH23/252/HS

36V 36V DC

Encoder 

Brushless BRUSHLESS



CODICE	DESCRIZIONE	PZ/PALLET
BH23/252/HS	Electromechanical articulated motor BRUSHLESS HIGH SPEED, low voltage, super intensive use, with native encoder onboard, irreversible ideal for swing gates with leaf up to 2.5 meters of length. With mechanical stopper in opening and closing and with standard version of short arms.	44

SPECIFICHE TECNICHE PRODOTTO	
Power line supply	230V AC - 50Hz
Motor power supply	36V
Power rating	160W
Frequency of use	Intensive use
Torque	50 - 200 N m
Operating temperature	-20+55° C
Protection level	IP43
Reductor Type	Irreversible
Manoeuvre speed	1,5 - 4 Rpm
Opening time at 90°	10-18 s
Limit switch	Mechanical stopper in opening and closing
Encoder	Digital native encoder SENSORLESS 48 PPR
Operating cycles per day (opening/closing - 24 hours no stop)	1200
Maximum dimension product in mm (L x W x H)	230 x 190 x 284
Product weight packed (Kg)	13
Number items per pallet	44

DIMENSIONI

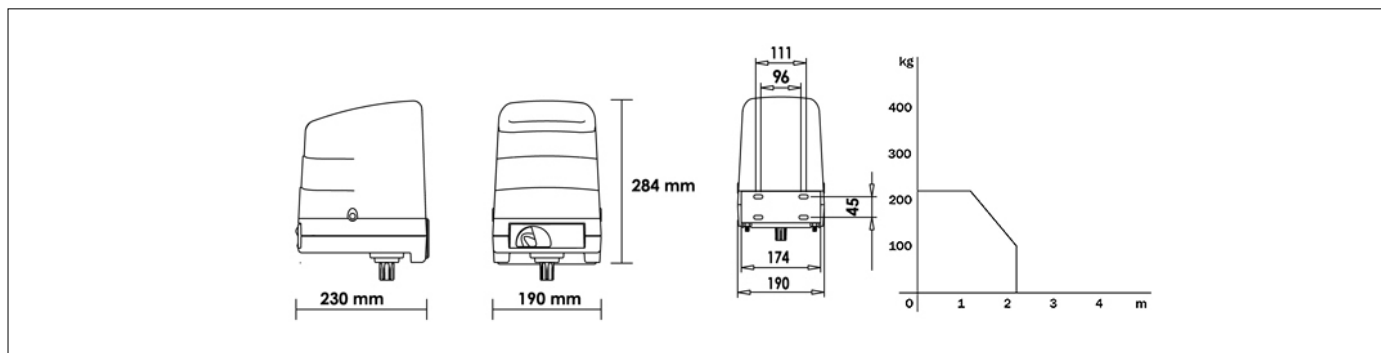

DIMENSIONS

PREDISPOSIZIONI INSTALLAZIONE STANDARD

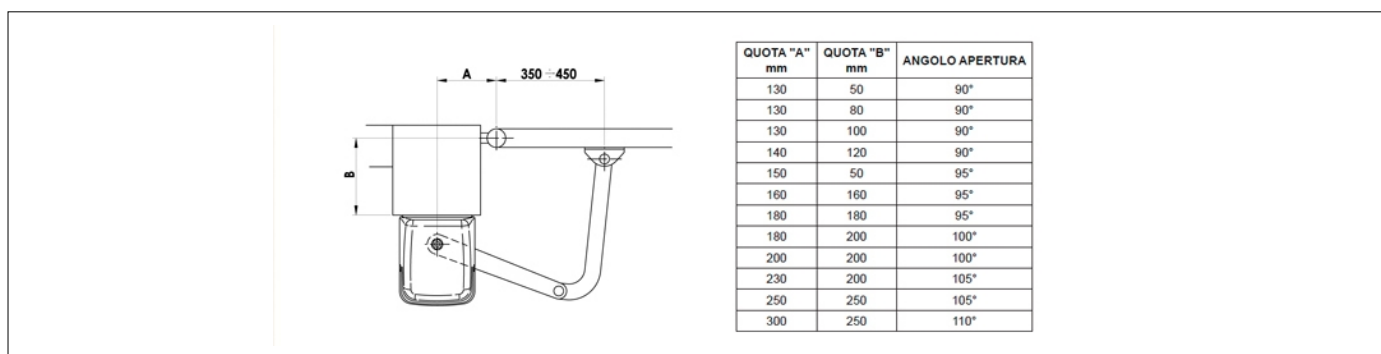

PREDISPOSIZIONE PER L'INSTALLAZIONE STANDARD

PRODOTTI ACCESSORI



LT302
Arms short for articulated motor.

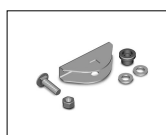

KT218
Gate pull bracket for series articulated.

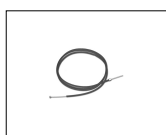

RL671
Metallic wire length 3mt for release from outside.



KT209
Plate for fixing to post H23 series.



R99/C/001
Signboard Automatic Opening".