



Ditec PWR50H/HV/HR

Automation for swing
gates

(translation of the original instructions)

IP2253EN
Technical Manual

Contents

Subject		Page
1.	General safety precautions	23
2.	Declaration of incorporation of partly completed machinery	24
2.1	Machinery Directive	24
3.	Technical specifications	25
4.	Standard installation	27
5.	Dimensions and gearmotor references	28
6.	Installation	29
6.1	Preliminary checks	29
6.2	Fastening the brackets	30
6.3	Using the positioning template	31
6.4	Installing the gearmotor	32
6.5	Adjusting the mechanical end stops	33
6.6	Adjusting the lever limit switch	33
6.7	Electrical connections	34
7.	Routine maintenance plan	35
8.	Troubleshooting	35
9.	Disposal	35
	Operating instructions	36
	General safety precautions for the user	36
	Manual release instructions	37

Key



This symbol indicates instructions or notes regarding safety, to which special attention must be paid.



This symbol indicates useful information for the correct operation of the product.

1. General safety precautions



Failure to respect the information given in this manual
may cause personal injury or damage to the device.
Keep these instructions for future reference

This installation manual is intended for qualified personnel only.

Installation, electrical connections and adjustments must be performed in accordance with Good Working Methods and in compliance with the present standards.

Read the instructions carefully before installing the product.

Incorrect installation could be dangerous.

Before installing the product, make sure it is in perfect condition.

Before installing the motorisation device, make all the necessary structural modifications to create safety clearance and to guard or isolate all the crushing, shearing, trapping and general hazardous areas.

Make sure the existing structure is up to standard in terms of strength and stability. The motorisation device manufacturer is not responsible for failure to observe Good Working Methods when building the frames to be motorised, or for any deformations during use.

The safety devices (photocells, safety edges, emergency stops, etc.) must be installed taking into account the applicable laws and directives, Good Working Methods, installation premises, system operating logic and the forces developed by the motorized gate. The safety devices must protect the crushing, shearing, trapping and general hazardous areas of the motorised door.

Display the signs required by law to identify hazardous areas.



Each installation must bear a visible indication of the data identifying the motorized gate.

When requested, connect the motorized gate to an effective earthing system that complies with current safety standards.

During installation, maintenance and repair operations, cut off the power supply before opening the cover to access the electrical parts.

The automation protection casing must be removed by qualified personnel only.



The manufacturer of the motorisation device declines all responsibility if component parts not compatible with safe and correct operation are fitted.

Only use original spare parts when repairing or replacing products.

The installer must supply all information on the automatic, manual and emergency operation of the motorised gate, and must provide the user with the operating instructions.

2. Declaration of incorporation of partly completed machinery

(Directive 2006/42/EC, Annex II-B)

The manufacturer Entrematic Group AB, with headquarters in Lodjursgatan 10, SE-261 44 Landskrona, Sweden, declares that the Ditec PWR50 automation for swing gates:

- is designed to be installed on a manual gate to form a machine pursuant to Directive 2006/42/EC. The manufacturer of the motorised gate must declare conformity with Directive 2006/42/EC (annex II-A) prior to initial machine start-up;
- complies with the applicable essential safety requirements indicated in Annex I, Chapter 1 of the Directive 2006/42/EC;
- complies with the Electromagnetic Compatibility Directive 2014/30/EU;
- complies with the RED Directive 2014/53/EU;
- the technical documentation complies with Annex VII-B of the Directive 2006/42/EC;
- the technical documentation is managed by the Technical Office of Entrematic Italy (with headquarters in Largo U. Boccioni 1 – 21040 Origgio (VA) – ITALY) and is available upon request, sending an e-mail to ditec@entrematic.com ;
- a copy of the technical documentation will be given to competent national authorities, following a suitably justified request.

Landskrona, 01-07-2016

Matteo Fino
(Chairman)

2.1 Machinery Directive

Pursuant to the Machinery Directive (2006/42/EC), the installer who motorises a door or gate has the same obligations as the manufacturer of machinery and as such must:

- prepare the technical data sheet which must contain the documents indicated in Annex V of the Machinery Directive;
(the technical data sheet must be kept and placed at the disposal of competent national authorities for at least ten years from the date of manufacture of the motorised door or gate);
- draw up the EC Declaration of Conformity in accordance with Annex II-A of the Machinery Directive and deliver it to the customer;
- affix the EC marking on the motorised door or gate, in accordance with point 1.7.3 of Annex I of the Machinery Directive.

3. Technical specifications

Tab. 3.0

	PWR50H	PWR50HV	PWR50HR
Type	Non-reversible	Non-reversible	Reversible
Stroke management (limit switch)	Mechanical close stops	Magnetic limit switches	Mechanical close stops
Power supply	24V $\overline{\text{DC}}$		
Max absorption	12A		
Power absorbed	65W nom / 288W max		
Max thrust	6000 N		
Maximum stroke	500mm		
Opening time	14+80 s / 90°		
Intermittence	200 cycles/day [max] 60 consecutive cycles at 20°C		
Lifespan	From 150,000 to 450,000 cycles based on the conditions indicated in table 3.1 (see the durability graphs of the product)		From 180,000 to 600,000 cycles based on the conditions indicated in table 3.1 (see the durability graphs of the product)
Operating temperature	-20°C / +55°C (-35°C + 55°C with NIO active)		
Degree of protection	IP44		
Dimensions (mm)	1044 x 100 x 120h		
Weight (kg)	10.5		

Chart 3.0

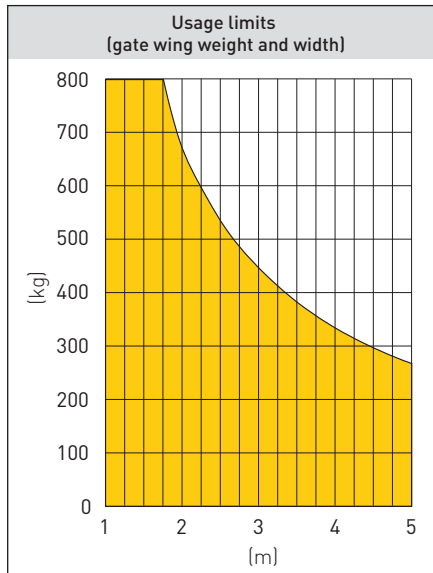

Tab. 3.1

Index of conditioning factors		
Gate wing weight	>150kg	-
	>200kg	-
	>300kg	-
	>400kg	-
	>500kg	10
	>600kg	20
Gate wing width	>3m	10
	>4m	20
Solid gate wing		15
Windy area		15
VA/VC/PO/PC speed setting higher than the default values		10
Force R1/R2 setting higher than the default values		10

The product lifespan is conditioned by the extent of other onerous conditions:
 with reference to Tab. 3.1, various corrective factors have been assessed in relation to the weight and width of the gate wing and the usage conditions; when taken as a whole, they affect the lifespan of the object (see Tab. 3.2).

Tab. 3.2

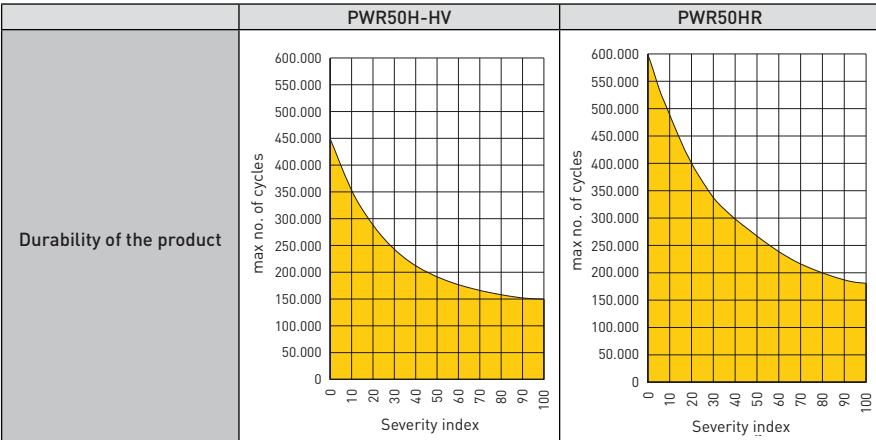

Two examples of the operator durability calculation are shown below:

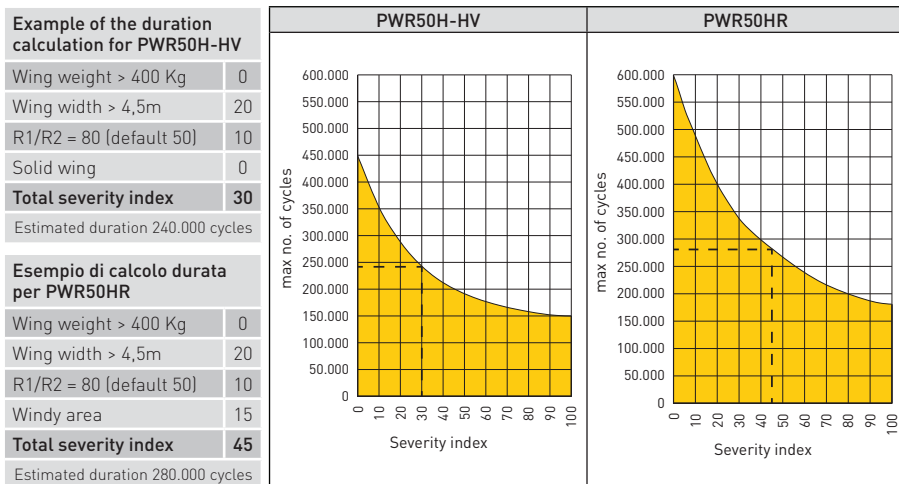

4. Standard installation

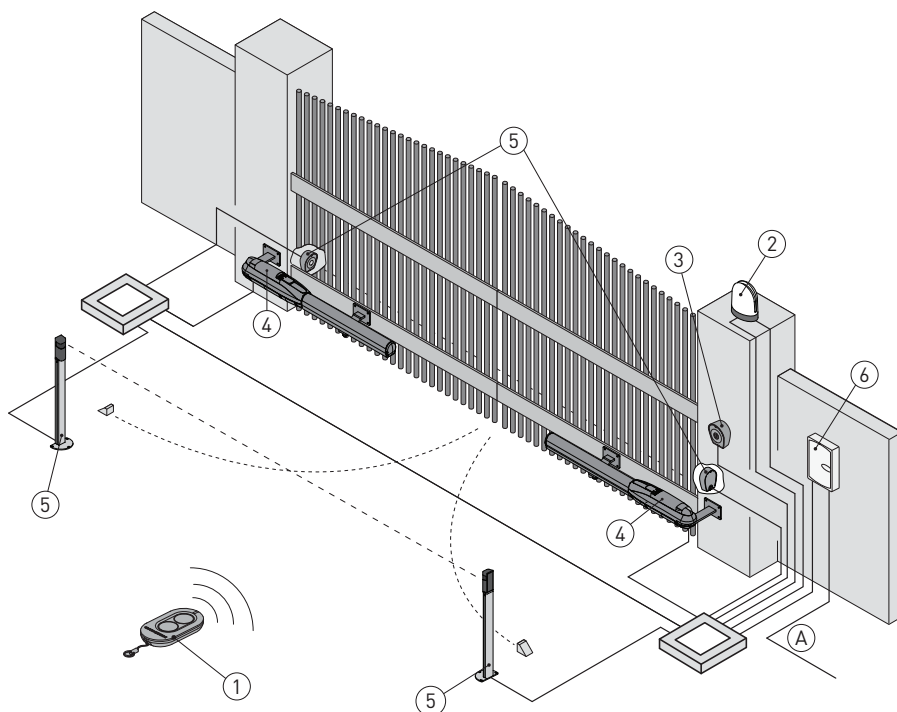

Ref.	Description	Cable
1	Transmitter	/
2	Flashing light	2 x 1mm ²
	Antenna (integrated in the flashing light)	coaxial 58 Ω
3	Key selector switch	4 x 0.5mm ²
	Digital combination wireless keypad	/
4	Actuator without magnetic limit switches	2 x 1.5mm ²
	Actuator with magnetic limit switches	3 x 1.5mm ²
5	Photocells	4 x 0.5mm ²
6	Control panel	3G x 1.5mm ²
A	Connect the power supply to a type-approved omnipolar switch (not supplied), with a contact opening distance of at least 3mm. Connection to the mains must be via an independent channel, separated from the connections to the command and safety devices.	

5. Dimensions and garmotor references

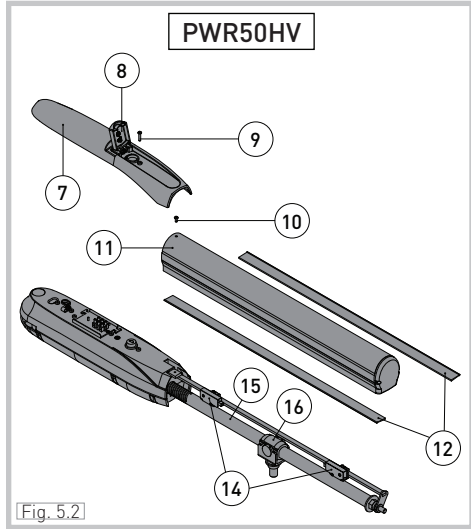
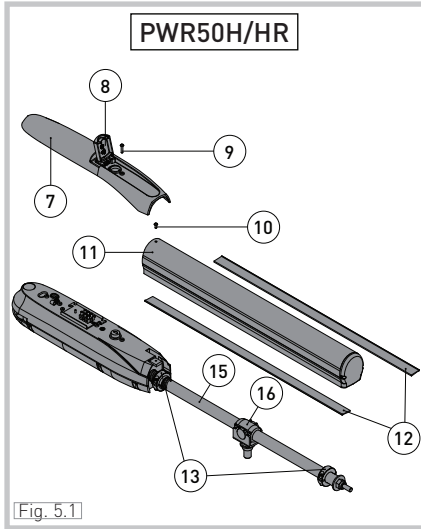

Ref.	Description
7	Rear cover
8	Release lock window
9	Screw for fastening the rear cover
10	Screw for fastening the front cover
11	Front cover
12	Protective brushes
13	Mechanical close stops
14	Magnetic limit switches
15	Drive screw
16	Split nut + magnet

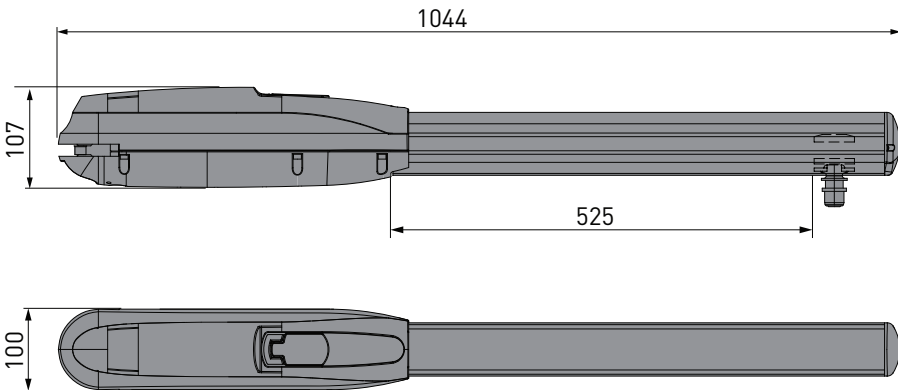

6. Installation

The declared operating and performance features can only be guaranteed with the use of EN-TREMATIC accessories and safety devices.

Unless otherwise specified, all measurements are expressed in mm.

6.1 Preliminary checks

Make sure the gate structure is sturdy and the hinges are lubricated and smooth. If possible, fit an opening and closing stop. Otherwise, use the built-in mechanical stops and/or the electric limit switches (optional) if available. The mechanical construction elements must comply with the requisites of Standard EN12604.



The automation fastening point varies according to the space available and the gate to be automated. The installer must therefore choose the best solution to ensure that the system works correctly in each individual situation.

The installation measurements indicated in the table allow you to choose the values of [A] and [B] on the basis of the required opening angle and in relation to the on-site spaces and overall dimensions. Increasing measurement [A], you reduce the opening approach speed.

Reducing measurement [B], you increase the gate opening angle.

Measurements [A] and [B] must, however, be compatible with the effective piston stroke.

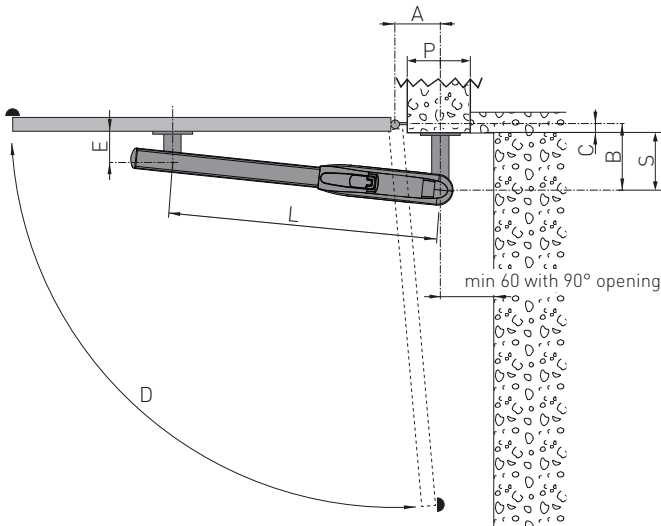

Tab. 6.1

A	B	C	S	D	E	L	P min
200	190	20	170	120°	120	910	220
200	200	50	150	110°			220
100	220	50	170	90°			120
130	210	70	140	95°			150
170	220	100	120	95°			190
200	190	100	90	100°			220
150	220	150	70	95°			170
130	290	220	70	90°			150

6.2 Fastening the brackets

After selecting the most suitable point for fastening the front bracket [18] to the gate wing, to establish its height you must first size, position and fasten the rear bracket [17]. If necessary, shorten the rear bracket [17] following the indications given in Tab. 6.1.

- Once you have fastened the rear bracket [17] following the measurements given on page 12, fasten the front bracket [18] to the gate.
- With the gate fully closed, position the front bracket [18], respecting the measurement (L). Make sure the front bracket [18] and rear bracket [17] are properly levelled, as shown in the figures below, then fasten the front bracket [18] to the gate.

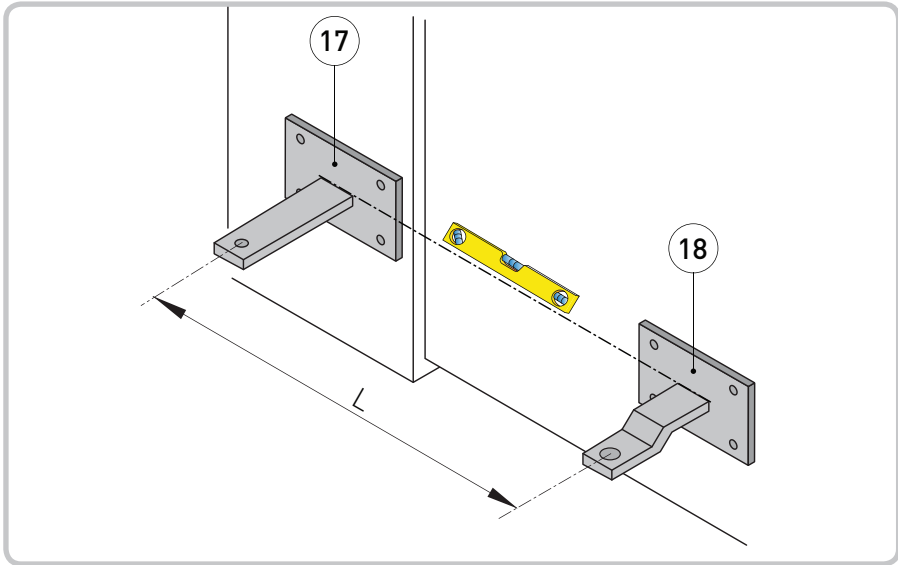

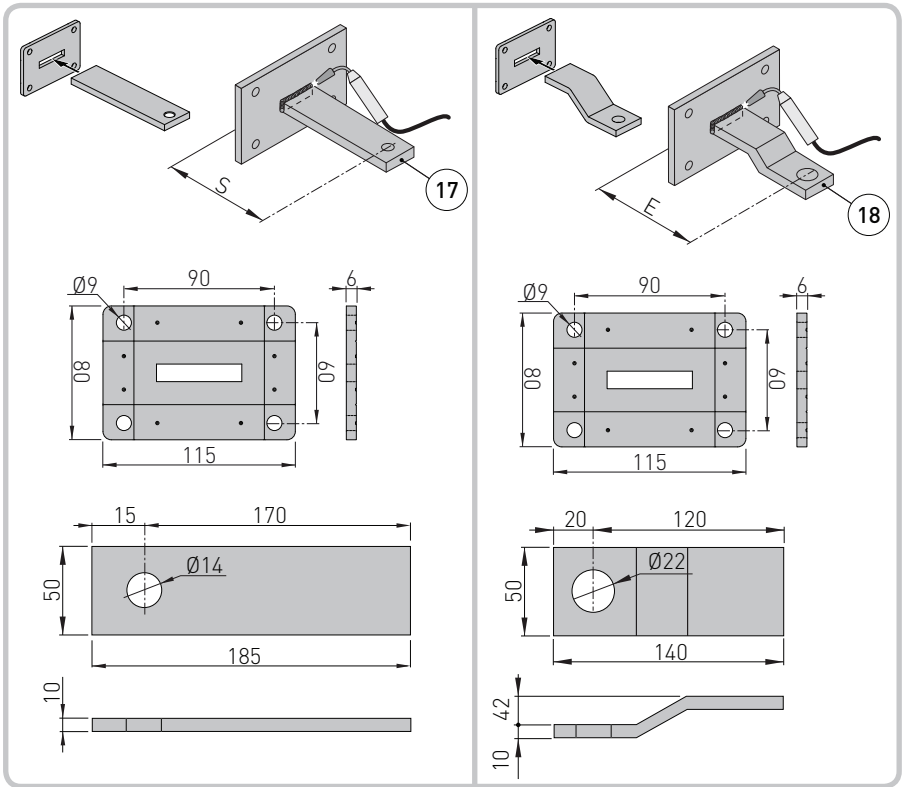

6.3 Using the positioning template

During installation, the bracket positioning operation can be greatly simplified by using the positioning template (optional accessory) which allows you to establish the correct position of the brackets and the distance between them. This avoids positioning errors and incorrect fixing hole alignment, thanks also to the built-in spirit-level.

The installation template is compatible with all the pistons of the PWR, Obbi and Luxo ranges.

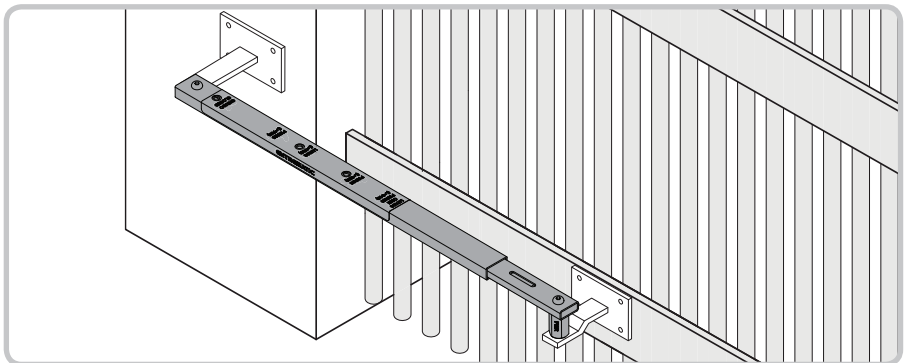

6.4 Installing the gearmotor

- Open the lock window [8], loosen the screw 6.3 x 19mm [9] and remove the rear cover [7]. Loosen the screw M4 x 8mm [10] and take out the front cover [11] as shown in the figure. Release the piston by inserting the key [23] in the relative lock [24] and turning it clockwise (see the USER INSTRUCTIONS).
 - Fasten the piston to the rear bracket [17] using the screw M8 x 45mm [19], the bush [20] and the washer \varnothing 24mm [21], then tighten the self-locking nut M8 [22] as far as it will go.
 - Open the gate wing manually and insert the front coupling pin [25] in the hole of the front fastening bracket [18]. Lock the pin in the bracket using the washer \varnothing 30mm [26] and nut M16 [27] supplied. Before installing the piston, grease the rotation points.
NB: pay special attention to the correct positioning of the washer on the brackets.
 - Insert the protective brushes [12] in the relative guides on the front cover [11] and push them well down (see Fig. 6.1). After making the adjustments (par. 6.5 and 6.6), insert the front cover [11] on the drive screw [25] and fix it in place using the screw [10].
- NB: make sure the drive screw [25] enters the head of the cover [11] correctly (detail shown in the figure below).

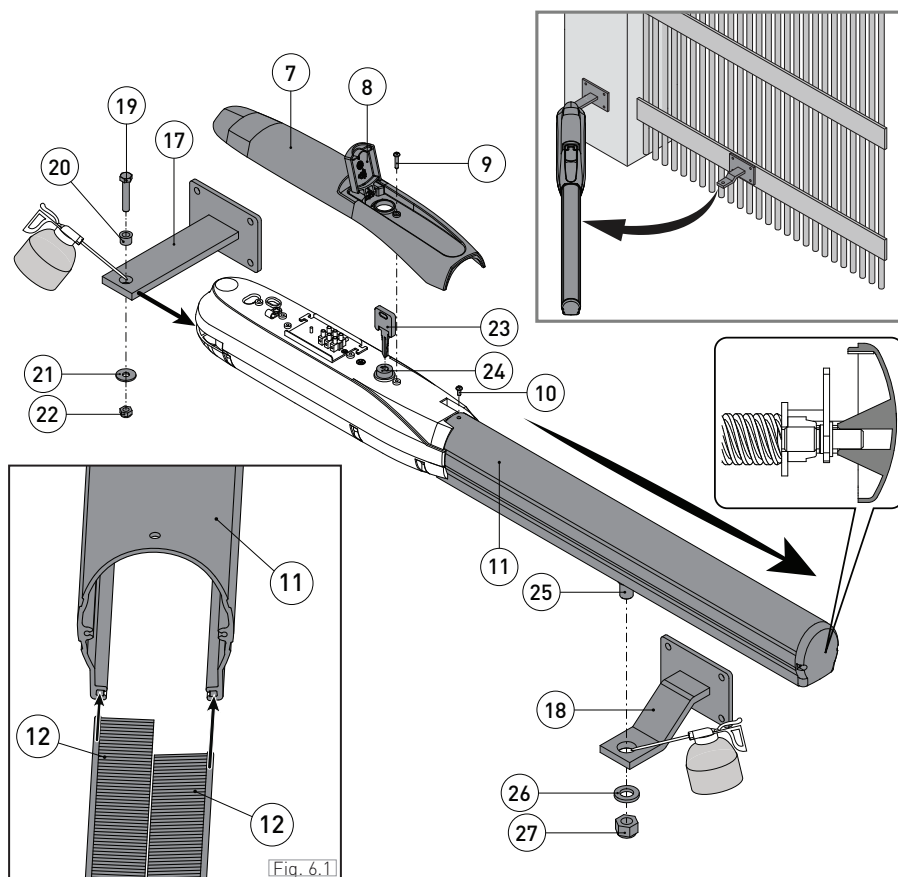

6.5 Adjusting the mechanical end stops (standard on PWR50H/HR)

Bring the gate wing to its fully open or closed position. Loosen the mechanical end stops with a 4mm Allen wrench, just enough so that they can slide along the drive screw, then move them up against the split nut and fix them in place.

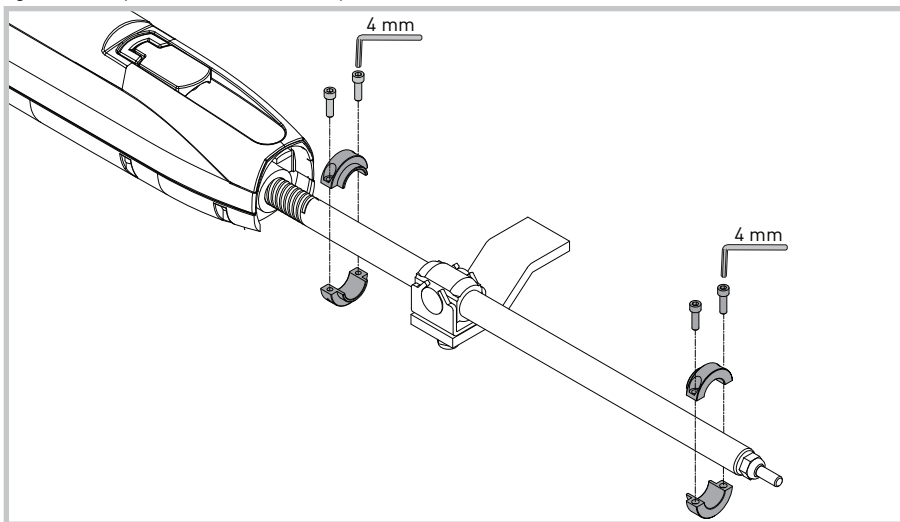

6.6 Adjusting magnetic limit switch (standard on PWR50HV)

Bring the gate wing to its fully open or closed position. Loosen the limit switches with a Phillips screwdriver, just enough so that they can slide along the guide, then bring them above the split nut [16] until the magnetic sensor is activated. Fix them in place.

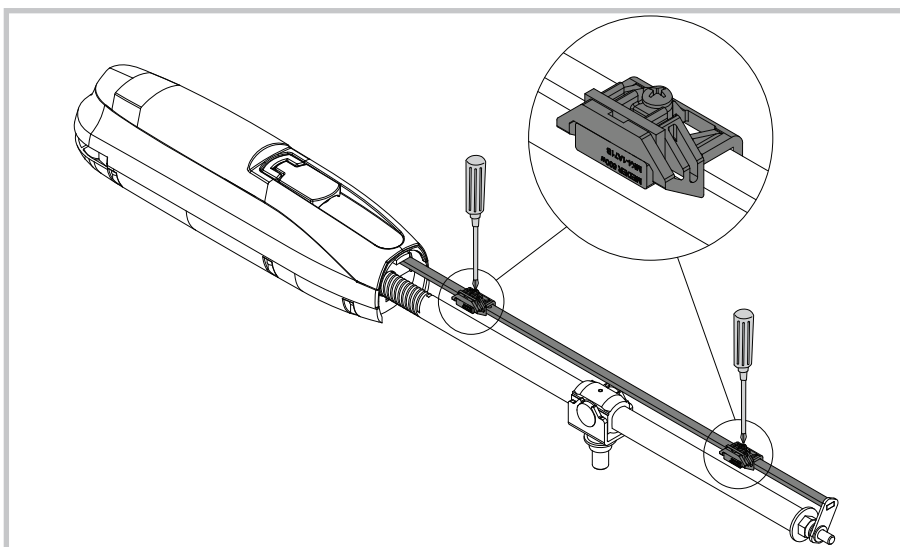

6.7. Electrical connections

The PWR50H/HR/HV gearmotors can be connected to the LCU40H control panels.

To connect the automation to the control panel, proceed as follows:

- Remove the rear cover [7] as explained in paragraph 6.4.
- Fit the cable gland on the automation, inserting it in the relative threaded hole in the metal fusion (Fig. 6.2 and 6.3).
- Connect the various wires as shown in the electrical diagram in Fig. 6.4.
- Fasten the rear cover [7] to the gearmotor.

The electrical connections and start-up of the PWR50H/HR/HV gearmotors are explained in the installation manuals of the LCU40H control panels.

To increase the protection of the motor cable, a corrugated flexible tube can be used.

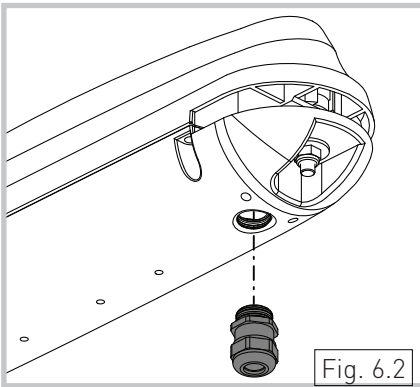

Fig. 6.2

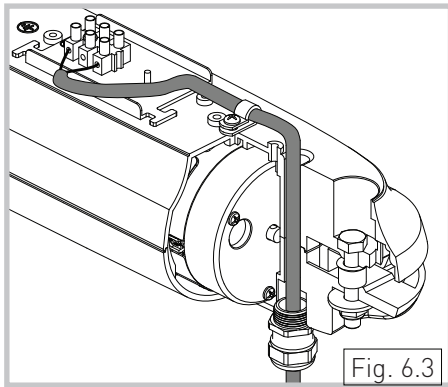

Fig. 6.3

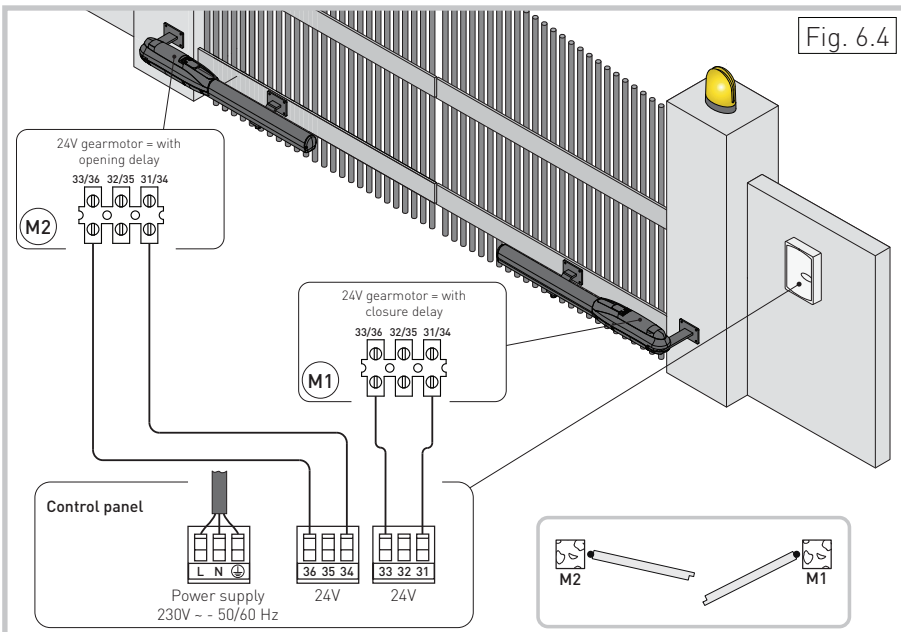

Fig. 6.4

7 . Routine maintenance plan

Carry out the following operations and checks every 6 months or 36.000 cycles.

Disconnect the 230V~ power supply and batteries (if present):

- Clean and lubricate the gate rotation pins, hinges and drive screw with neutral grease.
- Check the state of wear of the brushes [12], and replace them if necessary.
- Check the resistance of the fixing points.
- Check the electrical connections are in good condition.

Reconnect the 230V~ power supply and batteries (if present):

- Check the power adjustment.
- Check all the commands and safety functions (photocells) are operating correctly.
- Check the release system is working correctly.
- If batteries are fitted, check they are working properly (in continuity) by disconnecting the power supply and performing a series of consecutive operations. At the end, reconnect the 230V~ power supply.

8 . Troubleshooting

Problem	Possible cause	Operation
The gate doesn't open or close	No power supply.	Make sure the mains supply is active.
	Gearmotor released.	See the release instructions.
	Photocells occupied.	Check the photocells are clean and operating correctly.
	Permanent STOP command.	Check the STOP command or the control panel.
	Faulty selector.	Check the selector or control panel.
	Faulty remote control.	Check the condition of the batteries.
	Electric lock not working.	Check the lock is positioned and working correctly.
The gate opens, but it doesn't close	Photocells occupied.	Check the photocells are clean and operating correctly.

9 . Disposal



The packaging components (cardboard, plastic, etc.) must be separated out for recycling. Refer to the local disposal regulations before proceeding.

The packaging materials must not be discarded in the environment or left within reach of children, as they are a potential source of danger.



To dispose of electrical and electronic equipment, batteries and accumulators correctly, take the product to the differentiated disposal and recycling centres, respecting the regulations in force.



NB: for spare parts, refer to the spares price list.

Operating instructions

General safety precautions for the user

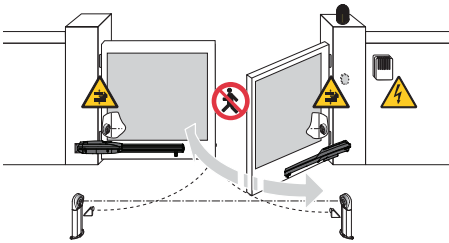

 These precautions are an integral and essential part of the product and must be supplied to the user.

Read them carefully since they contain important information on safe installation, use and maintenance.

These instructions must be kept and forwarded to all possible future users of the system.

This product must only be used for the specific purpose for which it was designed.

Any other use is to be considered improper and therefore dangerous. The manufacturer cannot be held responsible for any damage caused by improper, incorrect or unreasonable use.

Avoid operating in the proximity of the hinges or moving mechanical parts. Do not enter within the operating range of the motorised door or gate while it is moving.

Do not obstruct the motion of the motorised door or gate, as this may cause a dangerous situation.

The motorised door or gate may be used by children over the age of 8 and by people with reduced physical, sensorial or mental abilities, or lack of experience or knowledge, as long as they are properly supervised or have been instructed in the safe use of the device and the relative hazards.

Children must be supervised to make sure they do not play with the device, nor play/remain in the sphere of action of the motorised door or gate.

Keep remote controls and/or any other command devices out of the reach of children, to avoid any accidental activation of the motorised door or gate.

In the event of a product fault or malfunction, turn off the power supply switch. Do not attempt to repair or intervene directly, and contact only qualified personnel.

Failure to comply with the above may cause a dangerous situation.

Any repairs or technical interventions must be carried out by qualified personnel.

Cleaning and maintenance work must not be carried out by children unless

they are supervised.

To ensure that the system works efficiently and correctly, the manufacturer's indications must be complied with and only qualified personnel must perform routine maintenance on the motorised door or gate. In particular, regular checks are recommended in order to verify that the safety devices are operating correctly.

All installation, maintenance and repair work must be documented and made available to the user.

Only lock and release the door wings when the motor is switched off. Do not enter within the operating range of the wing.

Manual release instructions

In the event of a fault or a power failure, open the window (8), insert the key in the relative lock and turn it clockwise (as indicated by the arrow).

Release the electric lock (if present). Manually open the gate.

To lock the gate wings again, turn the key anti-clockwise.

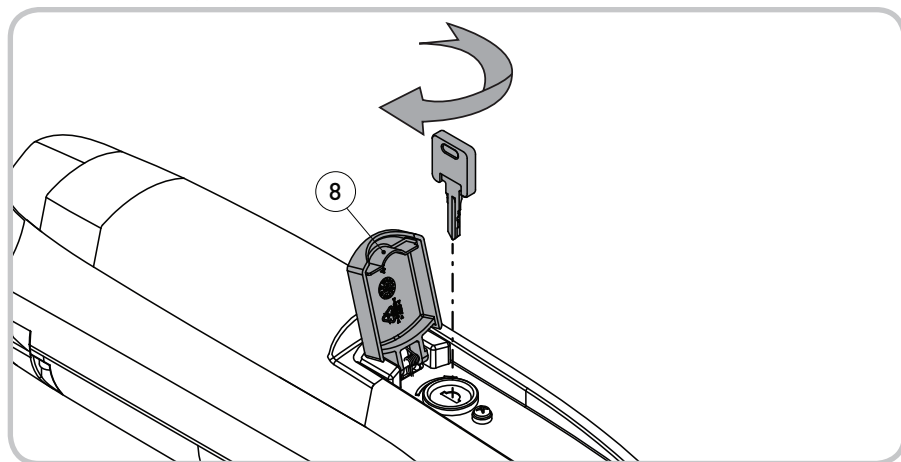

WARNING: Only lock and release the door wings when the motor is switched off.



For any problems and/or information, contact the Technical Service.

All the rights concerning this material are the exclusive property of Entrematic Group AB.

Although the contents of this publication have been drawn up with the greatest care, Entrematic Group AB cannot be held responsible in any way for damage caused by any possible mistakes or omissions. We reserve the right to make changes without prior notice.

Copying, scanning or changing in any way is expressly forbidden unless authorised in writing by Entrematic Group AB.

Entrematic Group AB
Lodjursgatan 10
SE-261 44, Landskrona
Sweden
www.entrematic.com

ENTRE//MATIC

